

## GT-B Type Monorail Trolley

### Features:

- Single hanging beam design, compact structure, forged wheels, integrated mobility
- Curved wheel rim, widely suitable for I, H steel or other homemade tracks
- High quality sealed roller bearings ensure flexible wheel operation
- Reasonable collocation of used gaskets can be applied to different rail width requirements
- Equipped with curved ear wall panel insurance protection to ensure safe operation

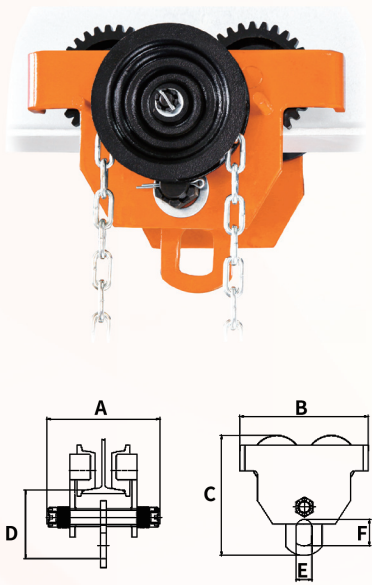

Model	GT-B1	GT-B2	GT-B3	GT-B5	
Capacity (kg)	1	2	3	5	
Standard Height(M)	3	3	3	3	
Test Load(N)	12.5	25	37.5	62.5	
Pull(N)	42.4	80	112	175	
Min Radius curve(M)	1	1.1	1.3	1.4	
Dimension(mm)	A	260	284	312	365
	B	250	270	316	358
	C	214	228	304	333
	D	118	125	165	183
	E	29	30	46	44
	F	46	46	76	73
Beam Width (mm)	75-125	100-150	100-150	125-175	
Net Weight(kg)	11	15	25	33	

## PT-B Type Monorail Trolley

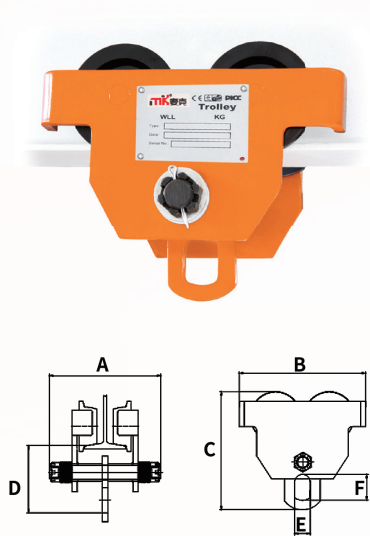

Model	PT-B0.5	PT-B1	PT-B2	PT-B3	PT-B5	
Capacity (kg)	0.5	1	2	3	5	
Test Load(N)	0.625	12.5	25	37.5	62.5	
Min Radius curve(M)	0.9	1	1.1	1.3	1.4	
Dimension(mm)	A	198	220	243	268	305
	B	204	250	270	316	358
	C	188	214	228	304	333
	D	113	118	125	165	183
	E	22	29	30	46	44
	F	36	46	46	76	73
Beam Width (mm)	72-125	75-125	100-150	100-150	125-175	
Net weight(kg)	6	8	11	22	30	

• Note:We reserve the right to change parameters without prior notification.