

Grade 80 Clevis Bent Hook

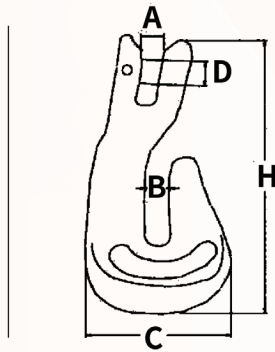

Features:

- Designed for Grade 80 alloy steel lifting chain and wire rope
- Use to shorten or hold a length of chain
- Prevent slip-off by engaging chain through narrow gap and resting ridges
- Capacity, brand name "PASAK" embossed on the products
- Material: High Tensile Drop Forged Alloy Steel
- Construction: Quenched and Tempered
- Safety Factor 4:1

Model	Capacity (t)	Chain (mm)	Dimension(mm)					Net Weight(kg)	Pcs/Pack
			A	B	C	D	L		
8-045-08	2	7-8	10	10	59	9	107	0.5	25

Grade 80 Clevis Grab Hook

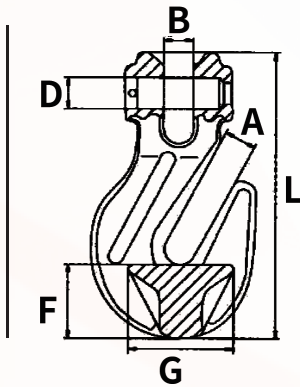

Features:

- Designed for Grade 80 alloy steel lifting chain and wire rope
- There is a wing on the hook which can strengthen the loading and let the chain get through smoothly and use for shortening or holding the chain
- Prevent slip-off by engaging chain through narrow gap and resting ridges
- Clevis opening prevents the use of wrong chain size and can save the connecting link cost for the alloy chain
- Capacity, brand name "PASAK" embossed on the products
- Material: High Tensile Drop Forged Alloy Steel
- Construction: Quenched and Tempered
- Safety Factor 4:1

Model	Capacity (t)	Chain (mm)	Dimension(mm)						Net Weight(kg)	Pcs/Pack
			A	B	D	F	G	L		
8-55-08	2	8	10.9	10	9	24.3	30.8	93	0.34	45
8-55-10	3.15	10	12.7	12.2	13	31	45	126	0.76	40
8-55-13	5.3	13	15	15.5	16	40	56	152	1.72	20
8-55-16	8	16	19.6	20	21	47	66.5	181.5	2.7	12
8-55-20	12.5	20	23.5	23.5	24	54	85	211	4.22	7
8-55-22	15	22	27	27	26	63	90	245	6.5	4
8-55-26	20	26	31	31	32	80	102	335	11.55	2

• Note: We reserve the right to change parameters without prior notification.